

Mini Beads Bracelet and Earring Sets



YOU WILL NEED:

Pegboard:

Mini Beads pegboard

Other:

- Mini Beads Tray:
- Neutral Colors
- Silver metallic cord
- Lobster claw clasps - 2
- 6mm jump rings - 6
- Silver ear wires - 2
- Brass ear wires - 2
- Adhesive gems
- 26T needle
- Needle-nose pliers
- Mini bead tweezers

Bead Colors You Will Use:

- Sand
- Tan
- Light Brown
- Brown
- Grey
- Black
- White
- Clear

Instructions

1. Slide the actual-size pattern under your clear pegboard and place your beads as shown.
2. An adult should fuse the designs—see bottom for further instructions.

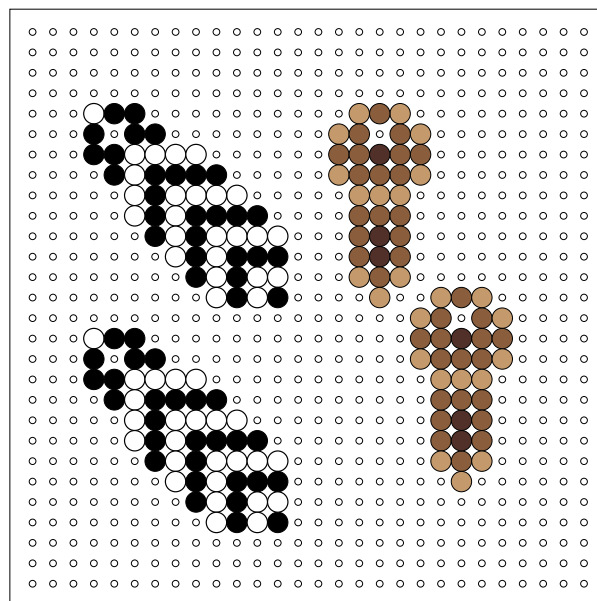





Earrings Assembly

For each earring, use a needle-nose pliers to open a jump ring. Attach the jump ring through the open hole in the fused piece. Add the ear wire, then close the jump ring.

Add adhesive gems if desired.

Bead Colors:

-  Tan
-  Light Brown
-  Brown
-  Black
-  White

Fusing Instructions—Only Adults Iron



1. Place your pegboard on a flat, heat-safe surface.
2. Set a household iron to the medium setting. Place ironing paper over the pegboard. In a circular motion, begin to iron the project. Do not press down with the iron. When ironed properly, the beads will still have an open center. Let the design cool.
3. Remove the paper and bead design from the pegboard. Flip the design over to expose the non-fused side. Repeat step two. Let cool completely.

Beads need heat for about 10 seconds per side to fuse evenly. Depending on the size of the project, additional heating time may be required.

Bracelets

The design of each bracelet is completely up to you. Create stripes or segments of color, combining the colors in whatever way pleases you. The bracelets shown are one long strand that gets wrapped around the wrist 3 times, but you can create single strands if you wish—you will just need additional jump rings and clasps.

1. Cut a piece of cord 3 times the desired finished length of the bracelet. A standard bracelet is approximately 7" long—adjust as needed to fit your wrist. For a triple wrap, you need at least 21".

To stabilize the bead string as you work, cut a short piece of cord and run it through the first bead. Tape the cord to a table or counter as shown.

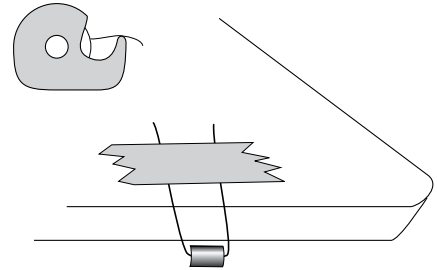

2. Run the needle and longer cord through the first bead twice to create a "stop."

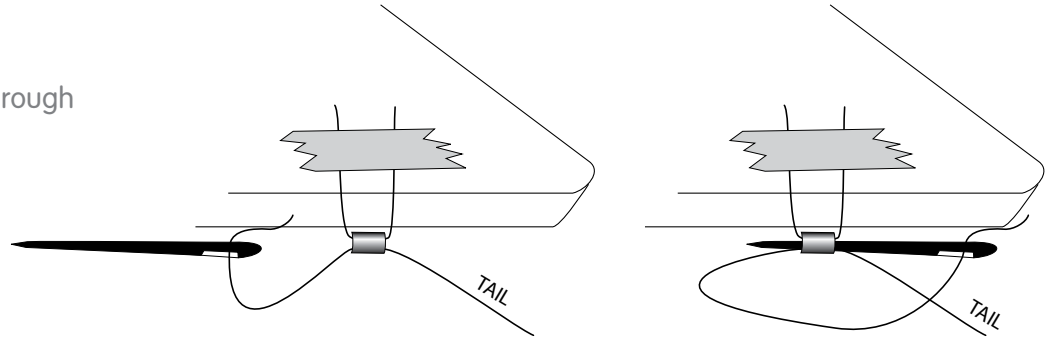

3. Add the second bead, then run the needle and cord through the first bead. Run the needle and cord through the second bead again to secure it.

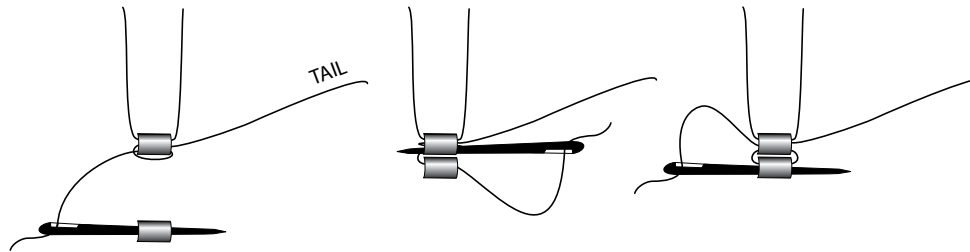

4. Add the third and succeeding beads in the same way. End the cord with a small knot. Remove the tape and short piece of cord.

Add a clasp on one end of the bracelet by knotting it to the stringing thread. Add a jump ring to the other end of the woven bracelet.

